

# Brio® Wardrobe Roll 50kg

Brio Australia  
 P: +61 2 87186718  
 W: [brio.com.au](http://brio.com.au)  
 E: [brio.sales@allegion.com](mailto:brio.sales@allegion.com)

Brio NZ  
 P: +64 9 829 0550  
 W: [brionz.com](http://brionz.com)  
 E: [nzinfo@allegion.com](mailto:nzinfo@allegion.com)

Brio UK  
 P: +44 191 2291224  
 W: [briouk.com](http://briouk.com)  
 E: [brio.sales.uk@allegion.com](mailto:brio.sales.uk@allegion.com)

Brio USA  
 P: +1 585 3195599  
 W: [briousa.com](http://briousa.com)  
 E: [brio.sales.usa@allegion.com](mailto:brio.sales.usa@allegion.com)

## Pack components

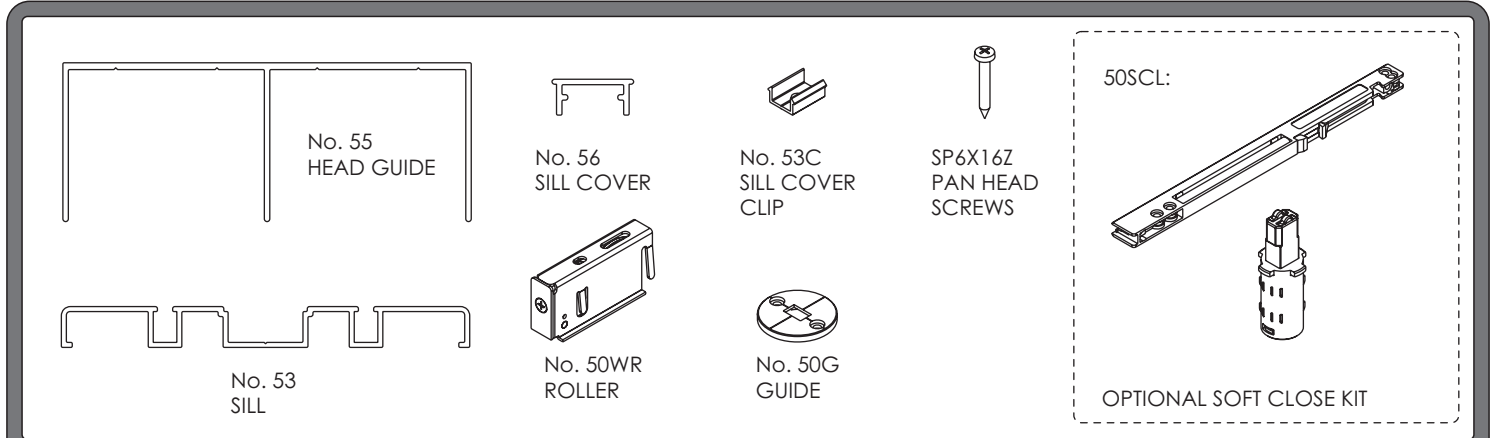

### PACKS

	55	53	56	53C	SP6X16Z	50G	50WR
WR50-12/2*	x1(1200)	x1(1200)	x1(1200)	x4	x18	x4	x4
WR50-15/2*	x1(1500)	x1(1500)	x1(1500)	x5	x21	x4	x4
WR50-18/2*	x1(1800)	x1(1800)	x1(1800)	x6	x24	x4	x4
WR50-24/3*	x1(2400)	x1(2400)	x1(2400)	x7	x31	x6	x6

\*Aluminium finishes: BA = black anodised, CA = clear anodised, PWT = white powdercoat

## Head and Sill Preparation

head, sill and sill cover cut to length 'W' (finished opening width)

Screw fixings to be staggered along length, avoiding 257mm from ends of head guide if using soft close

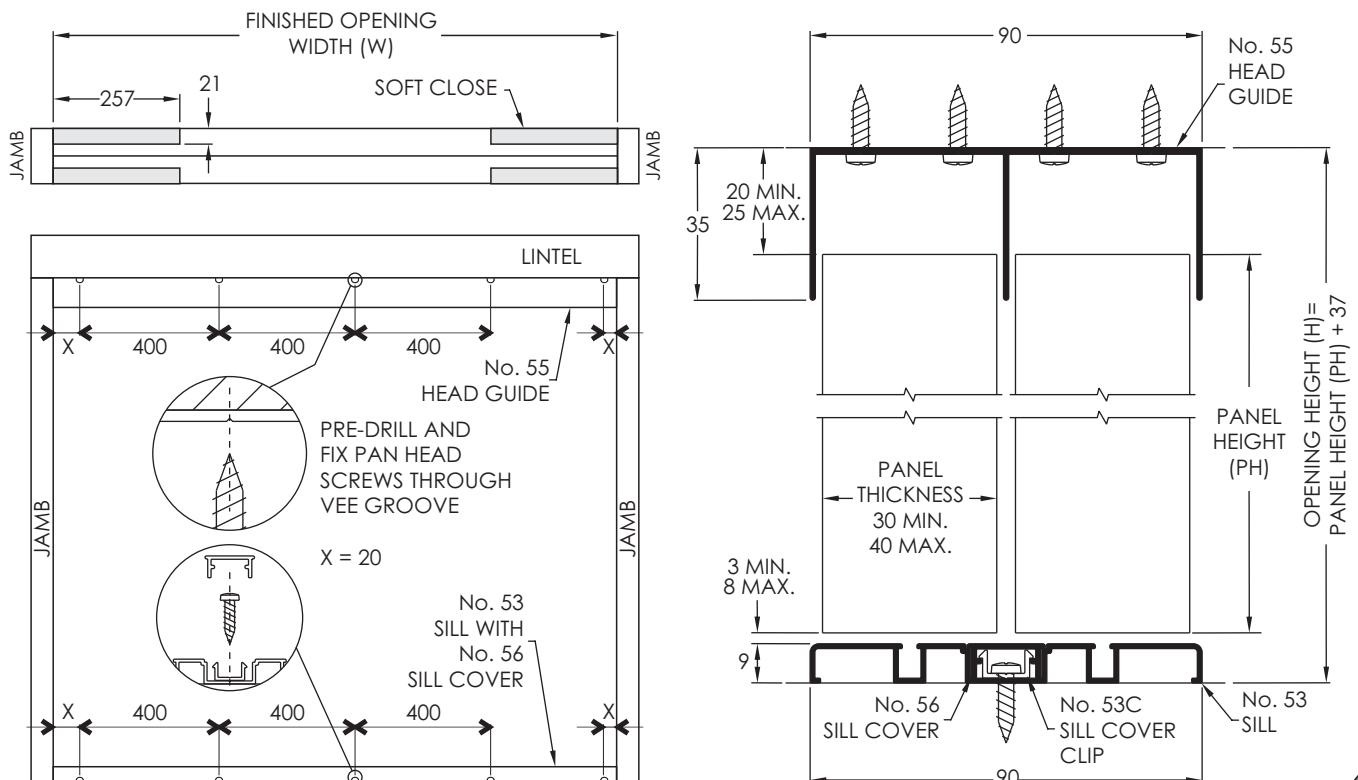

# Panel preparation and hardware installation

Panel height = Opening height - 37mm  
 2 panels: Panel width = (Opening width / 2) + 10mm (overlap)  
 3 panels: Panel width = (Opening width - 3 / 3) + 15mm (overlap)

Install panels as per numbered sequence below

## 2 PANEL CONFIGURATION

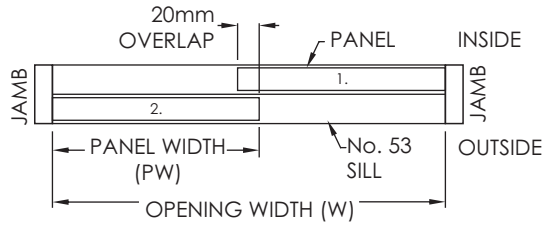

## 3 PANEL CONFIGURATION

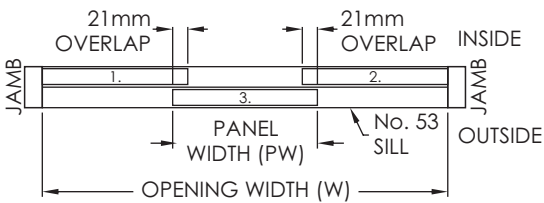

## Machine slot and drill adjustment hole for No. 50WR Roller

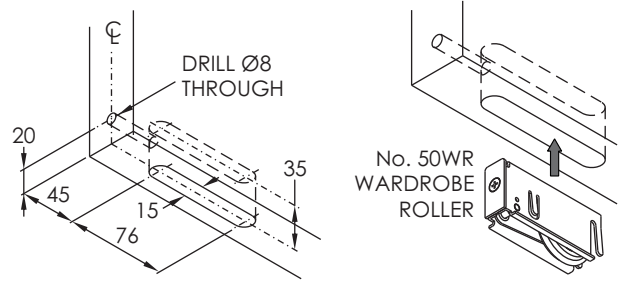

## Pre-drill holes for No. 50 Guide

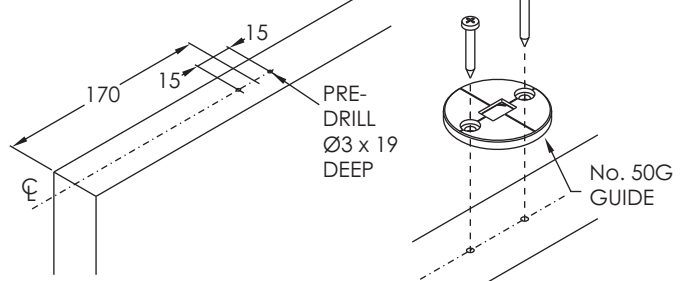

# Fitting soft close (optional)

Prepare panels for No. 50G guide and fit components. Fit soft close into No. 55 head guide using fixings supplied.

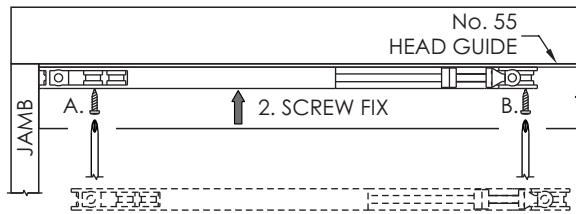
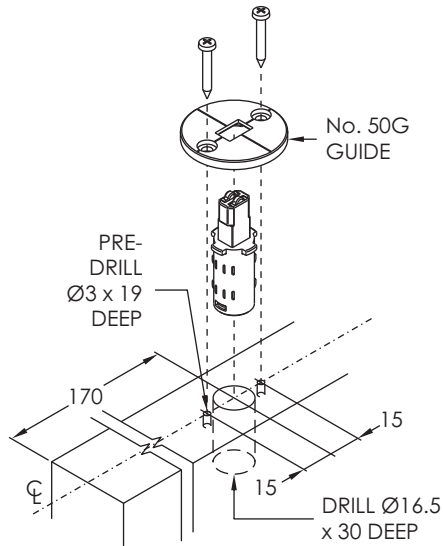

1. SOFT CLOSE TO BE FITTED AGAINST JAMB

Soft close layout inside No. 55 head guide

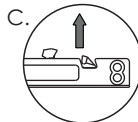
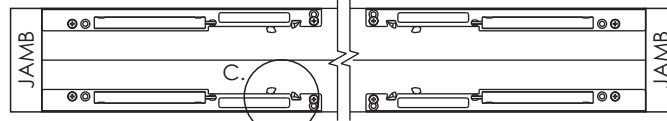

Catch of the soft close faces inward when mounting

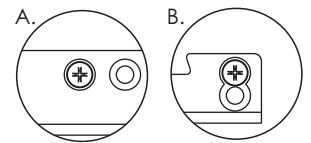

Prime soft closes before installing panels

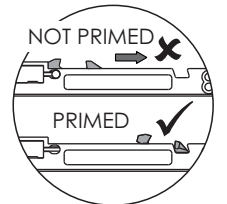

# Fitting panels

Adjust rollers up prior to installation.

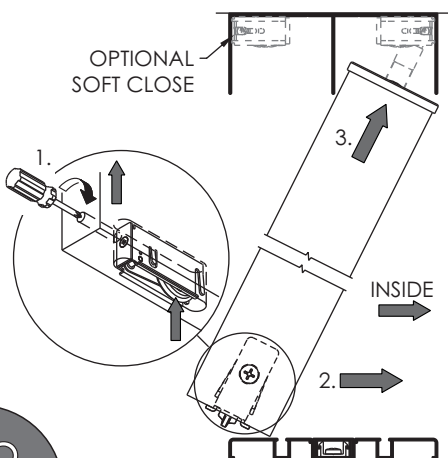

Soft close catch does not need to align to soft close yet.

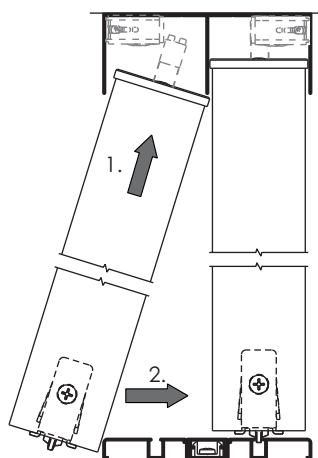

Do not slide panel until rollers have been adjusted down. Test panels.

